

**FILL-RITE**  
A GORMAN-RUPP COMPANY

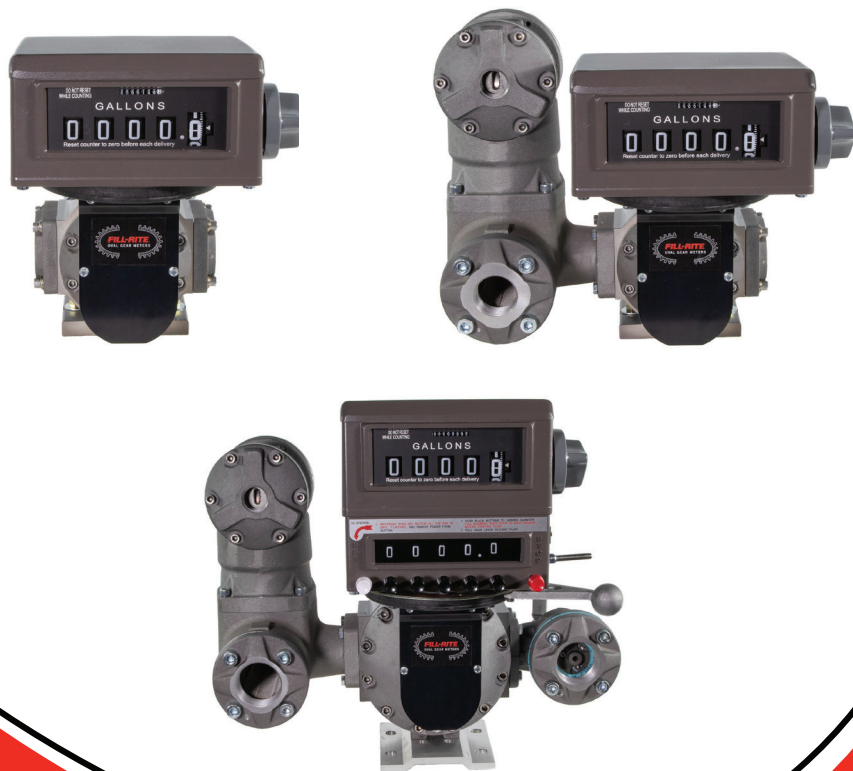

# TS SERIES ASSEMBLY MECHANICAL DRIVE

*Installation and Operation Manual*



MADE IN   
**USA**  
WITH GLOBAL MATERIALS

**GR**  
GORMAN-RUPP  
COMPANY

## Table of Contents

About This Manual .....	2
Safety Instructions.....	3
Operating Temperature .....	3
Operating Pressure .....	3
Installation .....	3
Start-Up & Operation.....	4
Calibration, Mechanical Flow Meters.....	6
Flow Meter Calibration .....	7
Warranty.....	8

### Thank You!

Thank you for your loyalty to the Fill-Rite brand. Your safety is important, so please read and thoroughly understand the procedures set forth in this manual. Protect yourself as well as those around you by observing all safety instructions and adhering to all danger, warning, and caution symbols. Please save these instructions for future reference and record the model, serial number, and purchase date of your Fill-Rite meter.

### IMPORTANT RETURN POLICY

For all warranty and product questions, please contact Fill-Rite Technical Support at 1 (800) 720-5192 or via email at [FillRiteTech@fillrite.com](mailto:FillRiteTech@fillrite.com) (M-F, 8 AM – 5 PM ET).

MODEL #	
SERIAL #	
PURCHASE DATE:	



## About This Manual

From initial concept and design through its final production, your Fill-Rite Oval Gear Meter product is built to give you years of trouble-free use. To ensure it provides that service, and to avoid injury or death, it is critical that you read this entire manual prior to attempting to install or operate your new product. Become familiar with the terms and diagrams, and pay close attention to the highlighted areas with the following labels:

<b>DANGER</b>	Indicates a hazardous situation which, if not avoided, will result in death or serious injury.
<b>WARNING</b>	Indicates a hazardous situation which, if not avoided, could result in death or serious injury.
<b>CAUTION</b>	Indicates a hazardous situation which, if not avoided, could result in moderate or minor injury.
<b>NOTICE</b>	Indicates information considered important but not directly hazard related.

At Fill-Rite, your satisfaction with our products is paramount to us. If you have questions or need assistance with your product, please contact us at 1 (800) 720-5192 or via email at [FillRiteTech@fillrite.com](mailto:FillRiteTech@fillrite.com) (M-F, 8 AM – 5 PM ET).

## Principle of Operation

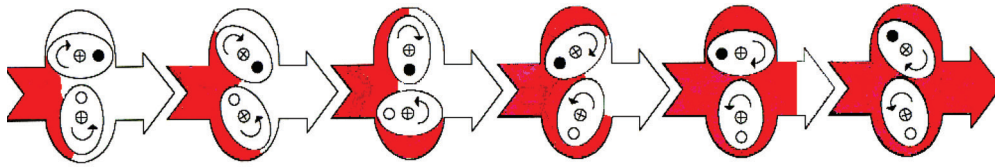

Positive Displacement meters have a measuring chamber, where inlet & outlet are separated by rotors, a rotating element or sliding vanes. As the liquid passes through the flow meter, it causes the rotors/element/vanes to turn, which forms the basis for volumetric measurement.

The **Oval Gear** metering principle is based on two elliptical (oval) gears, which turn on center on two horizontal shafts inside a measuring chamber formed by two overlapping cylinders. The oval gears have meshing teeth along their entire circumference, ensuring that the gears will maintain correct position in relation to each other at all times, without the use of timing gears.

The volume being transferred from the inlet to the outlet side (= volume measured), forms between the oval gear and the side of the measuring chamber, alternately in the upper and the lower half of the measuring chamber. In a full 360° rotation of the gears, four such known volumes are released to the downstream side of the flow meter.

The flow meter is 100% glandless with static O-ring seals only. Internal magnets are detected by a sensor (pulsar) mounted in flow meter case. The pulsar generates an electrical on/off signal, which can be used to drive a signal conditioner or an electronic register.

With precision machining and close internal tolerances, the slippage is minimal for superior linearity (accuracy) over a broad turndown ratio. Oval gear meters are largely unaffected by changes in liquid viscosity.

## Safety Instructions

Make sure that all necessary safety precautions have been taken, including proper clothing, personal safety equipment and fire safety equipment if required.

Before Start-Up of the Flow Meter, **make certain that:**

1. The meter is properly mounted, secured and piped.
2. All connections are tight.
3. All bleed and drain valves are closed.
4. Do NOT smoke near meter, or use meter near an open flame, when metering flammable liquids. Fire or Explosion could result.
5. This meter is not intended for use on liquids, which require 3A Sanitary equipment for human consumption. It may be used on edible liquids, which do not spoil easily, such as vegetable oils, liquid sweeteners & similar.

**Install the Flow Meter and Accessories in compliance with all applicable Local, State & Federal Construction, Electrical and Safety Codes.**

**Meters and Accessories are not approved for liquids having a vapor pressure at the maximum allowable temperature of not more than 0.5 BAR (7.25 PSI) above normal atmospheric pressure unless specifically noted.**

## Operating Temperature

TS Series assemblies are rated for:  
 -15°F/+176°F (-26°C/+80°C)

However:

- They are not suitable for cryogenic service.
- When operating temperature exceeds +150°F (+66°C), pressure rating is reduced. Please refer to Fill-Rite Technical Manual for details.

## Installation

- Positive Displacement meters are designed to operate full of liquid. The meter should be installed in a manner, so that it **remains full of liquid at all times**.  
 The flow meter is not designed to operate on air, but the design and materials of construction allow for operation on vapor for short periods of time without damage to the oval gears or flow meter internals.
- The **meter should always be supported** by bolting firmly to a solid platform or foundation. Never use the connecting pipe as the sole means of support.
- For most accurate measurement, the flow meter should operate with some backpressure (avoid delivering into an open vessel).
- The flow meter can operate with liquid going Left-to-Right, Right-to-Left, or Vertical Up, but it must be installed with **rotor shafts in horizontal position** (= with vertical end covers). Failure to observe this will impact negatively on flow meter accuracy and life of meter.

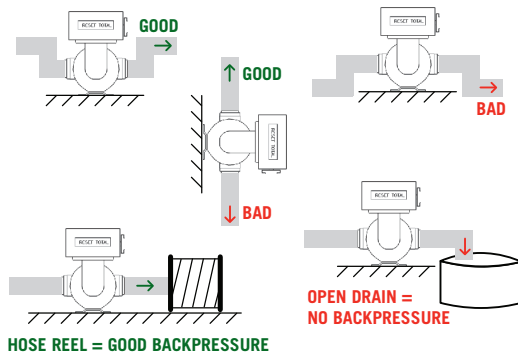

## Operating Pressure

Maximum non-shock operating pressure is:

- Flow Meter/Strainer : 150 PSI (10 BAR) (= +38°C)
- Air Eliminator/Valves : 150 PSI (10 BAR) (= +38°C)

The flow meter should never be operated in excess of this pressure. Care should be taken to eliminate thermal and hydraulic shock conditions, so that system pressure never exceeds the flow meter's Maximum Working Pressure rating.

- **Hydraulic shock** can be harmful to flow meter and other system components. Consideration to eliminate hydraulic shock should be given in selection of pump and design of the piping system.
- Protective caps installed in flow meter flanges prior to shipment should remain in place until you are ready to install in the piping system.
- Flow meters are designed to withstand a certain level of **vibrations**, such as might be experienced on retail delivery tank trucks. If the flow meter will be used in a system with higher levels of vibration, it must be protected with:
  - Vibration isolating pad under the mounting pedestal.
  - Vibration isolators (flexible hose) on both inlet & outlet.
- Apply pipe compound to male threads, to **install the two companion flanges**. Tighten to a position, that allows the meter to bolt to the companion flanges, free of pipe stress.
- It is recommended that a **Strainer** be installed upstream of each flow meter, to prevent damage from foreign matter, such as welding slag, pipe scale or parts breaking off other equipment.
  - If no fluid is specified, strainer basket comes standard with 40 mesh. We also offer: 20 mesh (std. with HV rotors) for use on high viscosity liquids, such as heavy fuel oil, automotive lube oils, liquid sugars, molasses, etc.
- Flush the system to remove all debris, scale and welding slag **prior to flow meter installation**. If this is not possible, temporarily remove rotors (oval gears), and reinstall after the system has been flushed.

### Installation (Continued)

- When installing the flow meter, consider future maintenance of both flow meter and accessories. The meter can be serviced in place, provided block (isolation) valves are included, and adequate space allowed.
- In critical installations a **bypass line is recommended**, so flow can continue while flow meter is being serviced.
- When an **Air Eliminator** is included in the flow meter assembly, the strainer/air eliminator must be in horizontal position, since the air eliminator operates on a gravity principle. A few drops of liquid may be expelled when the air eliminator vents, so vent ports should be piped back to storage or to a collection tank (sloping towards the tank).
- **Thermal relief valves are recommended**, and should be installed whenever it is possible to block (isolate) the flow meter between two valves. The pressure rise in a closed system, from just a few degrees increase in temperature, can be many times normal working pressure.
- **Connections for calibration** should be provided during installation. An easy means for diverting flow into a calibration vessel (or master meter) should be considered. Refer a diagram for the suggested installation is shown below.

The ideal installation incorporating all of these recommendations is shown at the bottom of the page.

### Start-Up & Operation

Very slowly fill the system with liquid, to avoid operating the flow meter on air or vapor. This can be accomplished in the following manner:

1. Throttle the meter inlet valve, and allow the system to fill slowly by gravity.
2. Gently open the outlet valve. Start the pump, and then gradually open the inlet valve, filling the meter slowly before fully opening the inlet and outlet valves.

In normal operations:

- Avoid sudden changes in temperature.
- Avoid sudden changes in flow rate.
- Gradually increase or decrease the flow rate.

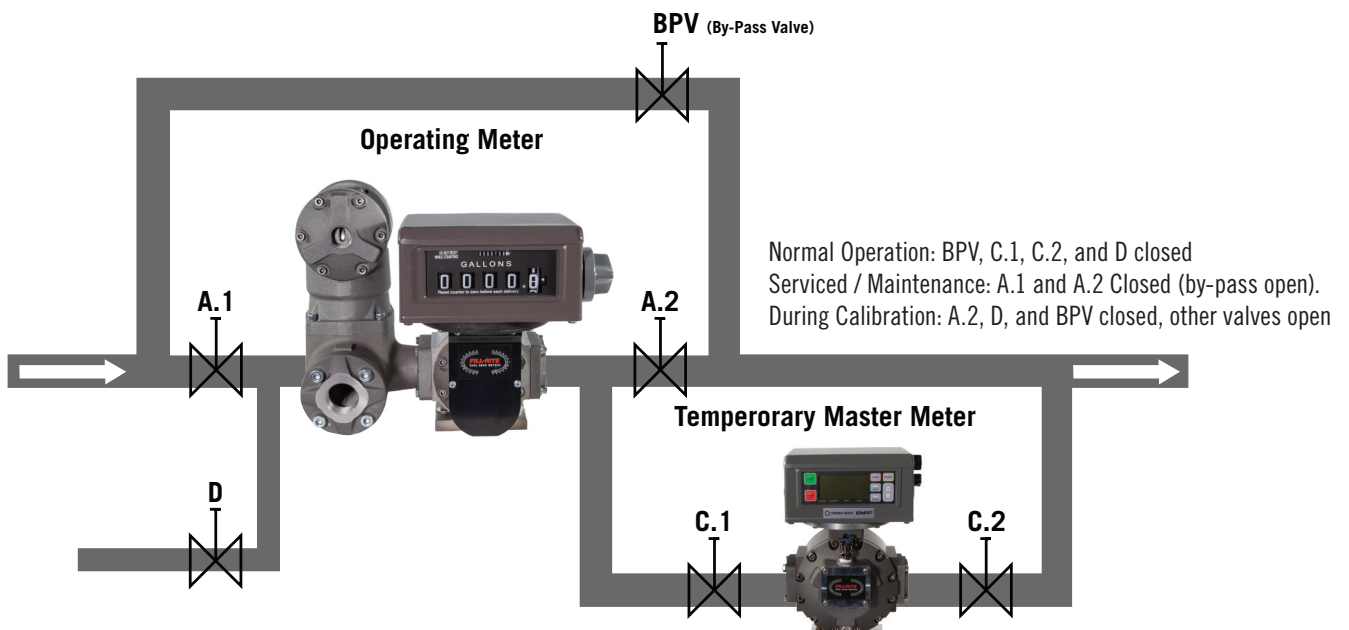

### Start-Up & Operation (Continued)

TS Series flow meters can operate in either direction. Standard assembly, when facing the flow meter, has the flow going Left-to-Right. A label with the word INLET is placed on the inlet flange, as assembled at the factory.

When the meter is first installed, check that the register is turning correctly when you start the flow. If it is not (or it is attempting to run backwards), check position of the face gear (11E) on the calibrator drive shaft (21A), and if necessary correct the position of the face gear versus the packing gland pinion (11D) as explained below.

**Left-to-Right flow** = Face gear below packing gland pinion

**Right-to-Left flow** = Face gear above packing gland pinion

The direction of flow can be changed in the field. This requires the following steps:

- Any accessories (strainer and/or preset valve) attached to the flow meter must be moved to the opposite side.
- Strainer inlet is standard from the front. When moving the strainer to Right-to-Left position, switch the inlet flange and strainer basket cover. If rear inlet is preferred, leave flange & basket cover as is, when moving the strainer.
- Standard outlet on Preset Valve or Air Check Valve is towards the front. When moving the valve to Right-to-Left position:
  - Air Check Valve: Rotate the valve 180°, then install tubing connecting air eliminator to the valve.
  - Preset Valve: Rotate the valve 180°. Disassemble the linkage, and reassemble mirror image to original assy.
- Reverse the position of the face gear (11E) on the calibrator drive shaft (21A).

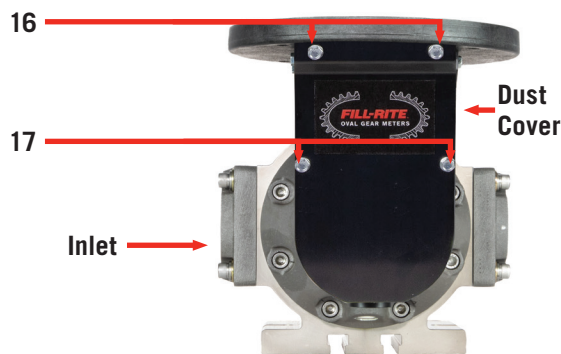

- First remove screws (16 & 17) to detach the dust cover (15) from the RAD (14 = Right Angle Drive) adaptor. Now refer to photo in next column.
- Notice position of the face gear (11E) on the calibrator drive shaft (21A) in relation to the packing gland pinion (11D).
- Remove E-ring (21F) with a screwdriver or small pliers. As shown, the E-ring is installed below the face gear, where it is not visible in the photo.
- Now loosen the set screw (18) with a 3/32" Allen wrench, to release the calibrator drive shaft bushing (21B).

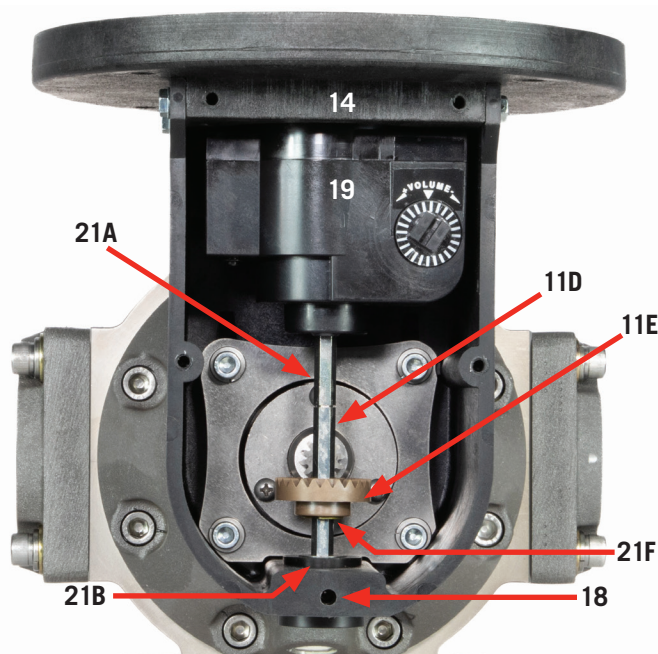

- Slide the calibrator drive shaft bushing (21B) out of the bottom of the RAD (14).
- Pull the calibrator drive shaft assembly out of the RAD.
- Remove the face gear (11E), and turn it 180°, so that the gear teeth are facing in the opposite direction from the original installation.
- Reassemble the parts in reverse order.
- Make sure that the calibrator drive shaft bushing flange (21B), is tight against the RAD (14).
- Tighten the hex nut (21C).
- Reinstall the E-ring (21F) in the appropriate groove (in the above example, the E-ring now goes into groove above the pinion).
- Inspect to make sure that there is slight backlash between the pinion gear (11D) and the face gear (11E). They must engage without binding or slipping.

21A = Drive shaft with 2 grooves

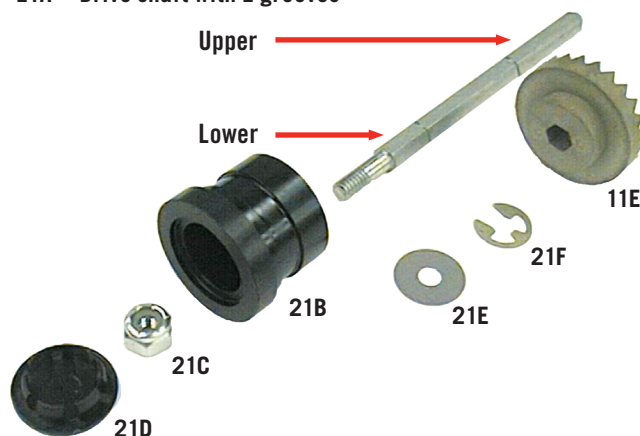

## Calibration, Mechanical Flow Meters

### Flow Meter Accuracy

All TS Series meters are accuracy tested prior to shipment. Data from accuracy testing is not supplied with flow meters, since results achieved on our test fluid do not apply to actual liquid of operation, unless the two liquids have identical viscosity characteristics.

The accuracy curve will not shift significantly at higher viscosities, even if the actual operating liquid has viscosities up to 500,000 cP.

Accuracy curves of individual flow meters vary slightly. Such minor variations are corrected in the mechanical calibrator. In our calibration procedure, the meter calibrator is set for zero error, when operating at 95-100% of capacity on 1 cSt viscosity fluid.

### Flow Meter Calibration in The Field

Since we cannot test on actual fluid of operation, it is the responsibility of the buyer to field calibrate:

- In place of service
- On actual operating liquid.

This will minimize errors arising from:

- A. Operation at a different flow rate.
- B. Operation on a fluid with different viscosity

It is recommended that written records be maintained on all flow meters. These records should include:

- Supplier and Service Department phone number.
- Date of installation.
- Details of maintenance performed.
- Date & result of each recalibration, with % change made on flow meter calibrator assy.

Mechanical TS Series meters have a mechanical drive train directly from the oval gears to the register. To convert oval gears movement to volume reading on the register, this drive train includes 3 calibration components:

- Packing gland pinion (11D) can have 12 or 24 teeth, while the face gear (11E) always has 24 teeth, resulting in a 1:1 or 2:1 ratio. The appropriate ratio depends upon flow meter model size & specific unit of calibration selected for the register.
- Mechanical calibrator (19). This component makes minute adjustments to final calibration to compensate for individual flow meter characteristics, viscosity of fluid being metered, and flow meter wear factor.
- A ratio gear plate installed below the mechanical register. Gearing on this gear plate is specific to flow meter model & unit of calibration selected. Optimum ratio is between 0.5000 & 5.0000 for best service life.



The mechanical register is common to all flow meter models, so it is possible to move registers from one flow meter to another. **Do NOT move the ratio gear plate from one flow meter to another.**

### Frequency of Recalibration

- In installations subject to local Weights & Measures regulations, frequency of recalibration must conform to such regulations.
- If local authorities issue regulations for non-W&M flow meters, such regulations must be observed.

When no regulations or standards apply, our recommendations are:

- Calibrate immediately after installation.
- Recalibrate after 15-30 days.
- Recalibrate after 180 days and again after 360 days.

After the run-in calibration and follow-up calibrations, it is possible to evaluate degree of change under normal operating conditions. Based on values found, and total volume being metered under normal operating conditions, decide whether a 6, 12 or possibly 24 month schedule should be adopted.

## Flow Meter Calibration

### Procedures & Methods

Flow meters subject to Weights & Measures regulations, or used in systems where the flow rate can fluctuate, should be tested at minimum, intermediate & maximum flow rates. In non-W&M service, a flow meter always operating at a steady flow rate, can be tested at that flow rate only.

All tests should be repeated 3 times to confirm repeatability. All tests should be of at least 60 second duration, to minimize the effect of flow meter error during start-up and shut-down.

- After dispensing a known volume (X) into an accurate prover, or through a Master Meter (MM), compare with register reading (Y) and calculate correction:

$$\frac{X - Y}{X} \times 100 = \% \text{ correction}$$

- When re-calibration has established that a correction is required, remove the dust cover (15) from the RAD (14 = right angle drive adaptor), by detaching screws (16 & 17).

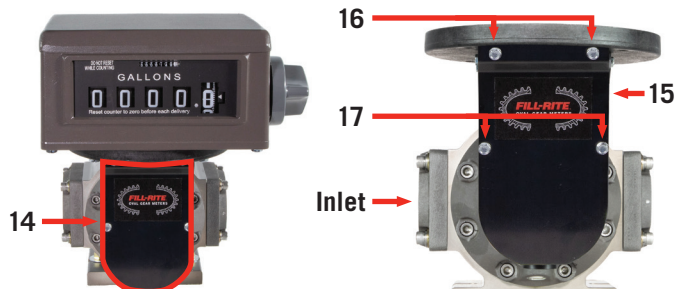

This provides access to the calibrator assembly (not shown), which has a dial on the front, and is marked with directions for + and - Volume. Each graduation of this dial represents approx. 0.06% change.

The dial has a slot for a screw driver in the center, so the setting can be changed. As you turn the center, you will hear two 'clicks' for each graduation mark. Each 'click' represents approximately 0.03% change in the setting.

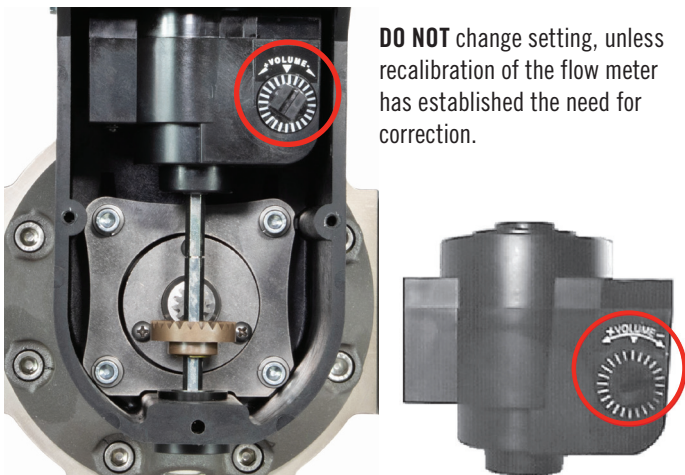

- When prover/master meter reading is less than flow meter register reading, add percentage calculated by turning the calibrator in the + volume direction.
- When prover/master meter reading is more than flow meter register reading, subtract percentage calculated by turning the calibrator in the - volume direction.

After correcting calibrator setting, circulate product through the flow meter for a few minutes. Then perform at least 3 more tests, to confirm flow meter accuracy & repeatability.

- If the flow meter does not repeat, it will likely require a new set of oval gears.
- Before ordering new gears, inspect the measuring chamber for scratches or wear. If the measuring chamber is scratched or scored beyond what can be smoothed with emery paper, flow meter case should be replaced.

Finally:

- Re-seal the flow meter.
- Enter date and % correction on the permanent flow meter record.

As long as degree of change is moderate, the flow meter is in good condition.

If there is a sudden significant jump in correction required, the oval gears are likely about worn out. Oval gear replacement should be considered now, rather than letting further wear cause oval gears to start rubbing on flow meter housing.

## Warranty

---

Fill-Rite Warranty does not extend to damage due to corrosion, salt deposits, or separation of chemicals – whether occurring during periods of operation or storage. Non-Fill-Rite items, such as electronic registers, are covered by the original manufacturer warranty, but will be handled through Fill-Rite if the register was supplied by Fill-Rite. Components added after shipment from Fill-Rite, such as hose, nozzles & similar, are the responsibility of the distributor or contractor selling the installation.

---

**FILL-RITE**<sup>®</sup>  
A GORMAN-RUPP COMPANY



Fill-Rite Company  
8825 Aviation Drive  
Fort Wayne, Indiana 46809 USA

T 1 (800) 720-5192  
1 (260) 747-7524  
F 1 (800) 866-4681



[fillrite.com](http://fillrite.com) | [sotera.com](http://sotera.com) | [gormanrupp.com](http://gormanrupp.com)