

KIT120SL SEAL ASSEMBLY

CHECK THE SHAFT ON YOUR PUMP TO DETERMINE IF IT HAS A "FACTORY CUT" GROOVE FOR A RETAINING RING.

A. Yes. Shaft has a retaining ring groove.

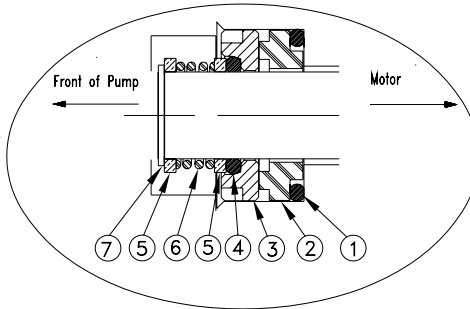
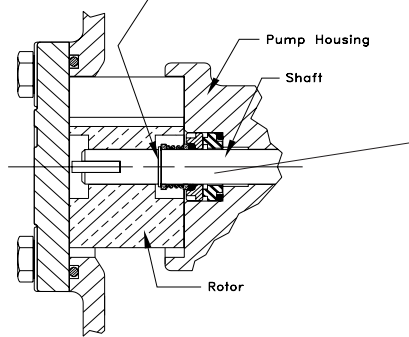

Item	Part No.	Description	Qty.
1	1200F6576	Big O-ring	1
2	1200F6555	Black, Carbon	1
3	SL001699-000	Stainless Steel	1
4	800F4449	Small O-ring	1
5	1200H0592	Washer	2
6	1200F6570	Spring	1
7	1200F6669	Retaining Ring	1

NOTE: New style rotor; deep cavity faces pump seal. See back for old style rotor.

INSTALLATION HINTS

1. Pump housing and shaft must be clean and free of defects.
2. Mating surfaces of black and white seal pieces must be clean.
3. Lubricate O-rings before installation.
4. Place big O-ring over shaft into pump housing cavity.
5. Place black carbon piece on shaft and push up against big O-ring.
6. If pump leaks out the weep hole after installing new seal, remove and inspect shaft, pump cavity and seal components for dirt or damage. Also, make sure big O-ring (1) is positioned correctly. Replace any damaged seal components, clean and reinstall. *If leakage still occurs, your shaft or pump housing may be damaged or worn out. Take pump to an authorized service center for repair.*

Continued on back

KIT120SL SEAL ASSEMBLY

CHECK THE SHAFT ON YOUR PUMP TO DETERMINE IF IT HAS A "FACTORY CUT" GROOVE FOR A RETAINING RING.

A. Yes. Shaft has a retaining ring groove.

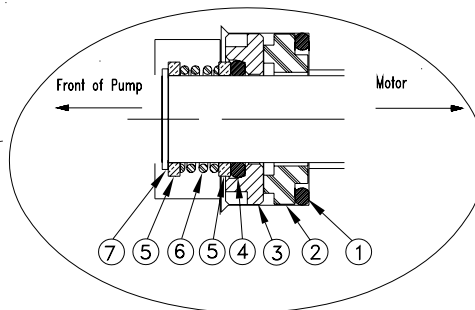
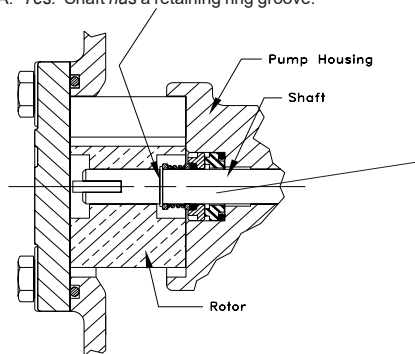

Item	Part No.	Description	Qty.
1	1200F6576	Big O-ring	1
2	1200F6555	Black, Carbon	1
3	SL001699-000	Stainless Steel	1
4	800F4449	Small O-ring	1
5	1200H0592	Washer	2
6	1200F6570	Spring	1
7	1200F6669	Retaining Ring	1

NOTE: New style rotor; deep cavity faces pump seal. See back for old style rotor.

INSTALLATION HINTS

1. Pump housing and shaft must be clean and free of defects.
2. Mating surfaces of black and white seal pieces must be clean.
3. Lubricate O-rings before installation.
4. Place big O-ring over shaft into pump housing cavity.
5. Place black carbon piece on shaft and push up against big O-ring.
6. If pump leaks out the weep hole after installing new seal, remove and inspect shaft, pump cavity and seal components for dirt or damage. Also, make sure big O-ring (1) is positioned correctly. Replace any damaged seal components, clean and reinstall. *If leakage still occurs, your shaft or pump housing may be damaged or worn out. Take pump to an authorized service center for repair.*

Continued on back

B. No. Shaft has no retaining ring groove (pumps built before 11/92).

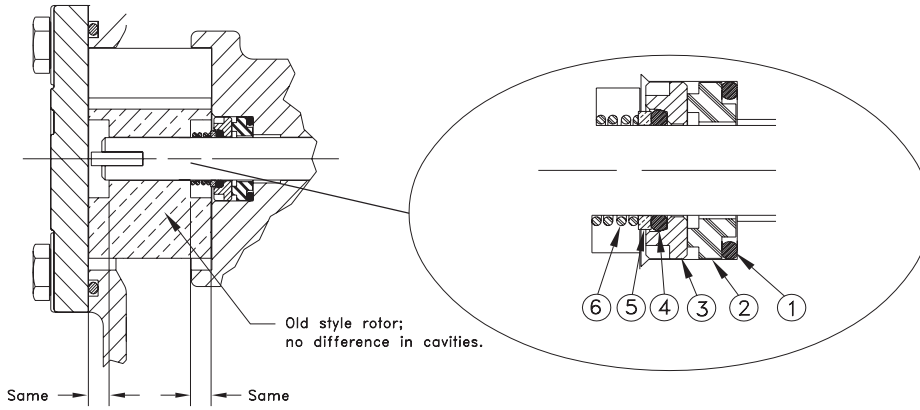

Item	Part #	Description	Qty.
1	1200F6576	Big O-ring	1
2	1200F6555	Black, Carbon	1
3	SL001699-000	Stainless Steel	1
4	800F4449	Small O-ring	1
5	1200H0592	Washer	1
6	1200F6570	Spring	1

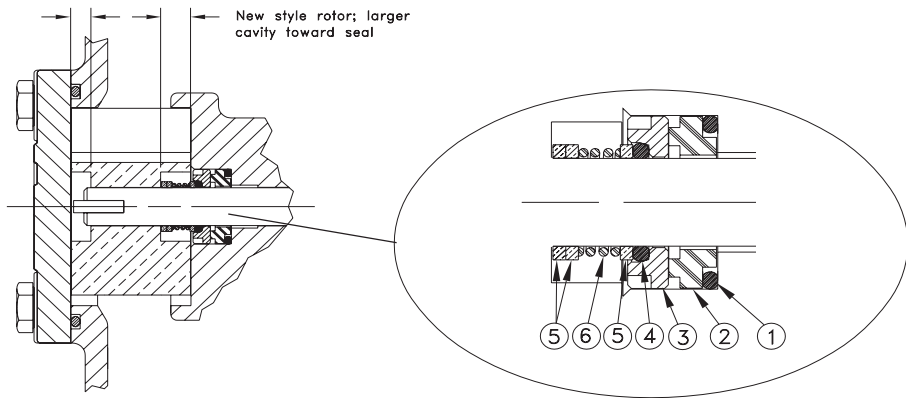

Item	Part #	Description	Qty.
1	1200F6576	Big O-ring	1
2	1200F6555	Black, Carbon	1
3	SL001699-000	Stainless Steel	1
4	800F4449	Small O-ring	1
5	1200H0592	Washer	3
6	1200F6570	Spring	1

KIT120SL REV. 3

B. No. Shaft has no retaining ring groove (pumps built before 11/92).

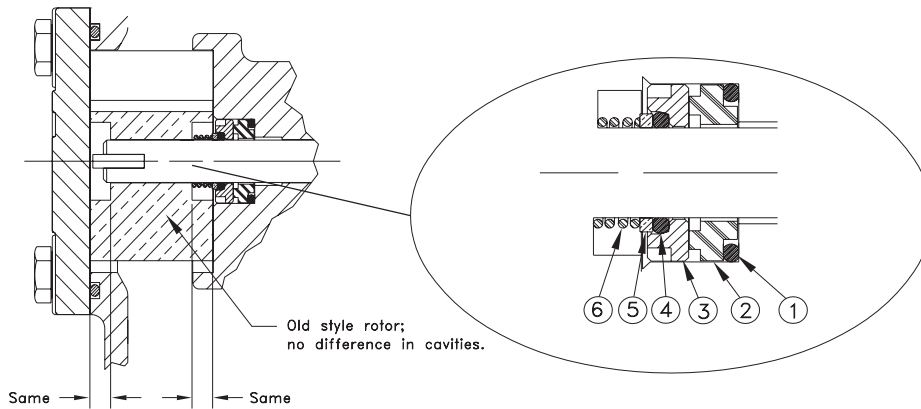

Item	Part #	Description	Qty.
1	1200F6576	Big O-ring	1
2	1200F6555	Black, Carbon	1
3	SL001699-000	Stainless Steel	1
4	800F4449	Small O-ring	1
5	1200H0592	Washer	1
6	1200F6570	Spring	1

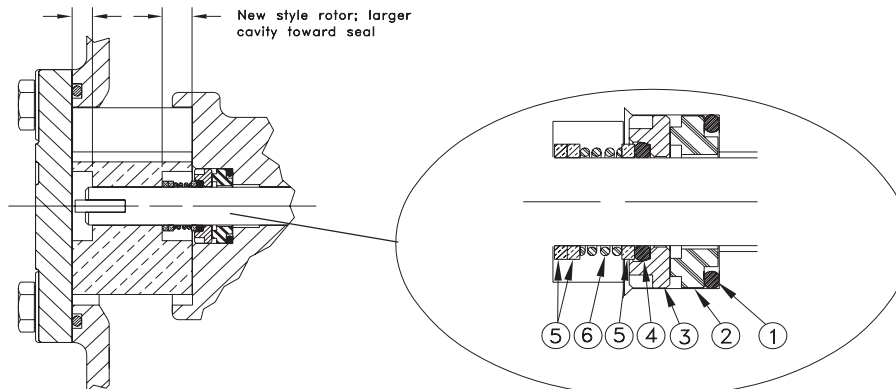

Item	Part #	Description	Qty.
1	1200F6576	Big O-ring	1
2	1200F6555	Black, Carbon	1
3	SL001699-000	Stainless Steel	1
4	800F4449	Small O-ring	1
5	1200H0592	Washer	3
6	1200F6570	Spring	1

KIT120SL REV. 3