

### 300 Series Nozzle Boot Installation

USE TWO LOWER HOLES IN  
NOZZLE BOOT FOR MOUNTING

NOZZLE BOOT

NOZZLE BOOT BRACKET

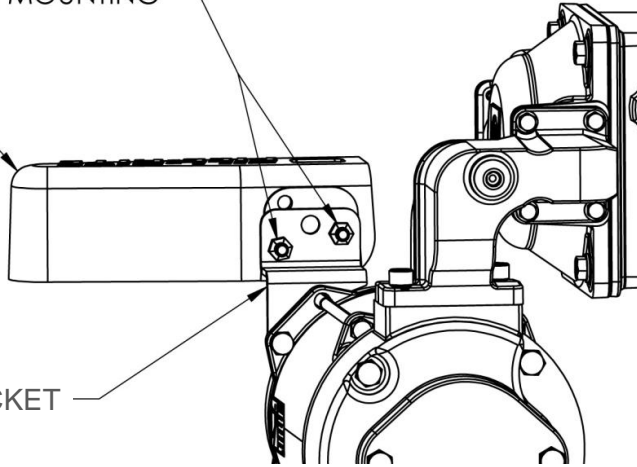

The nozzle boot is installed using the lower two screw holes on the side of the boot. Use supplied attaching hardware to install the nozzle boot.

When the nozzle is mounted correctly it will be in a horizontal position.

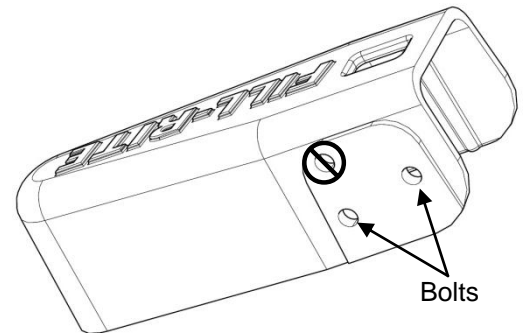

### 600\*, 1200\*, 2400\*, 3200\*\*, 4200\*, and 4400\* Series Nozzle Boot Installation

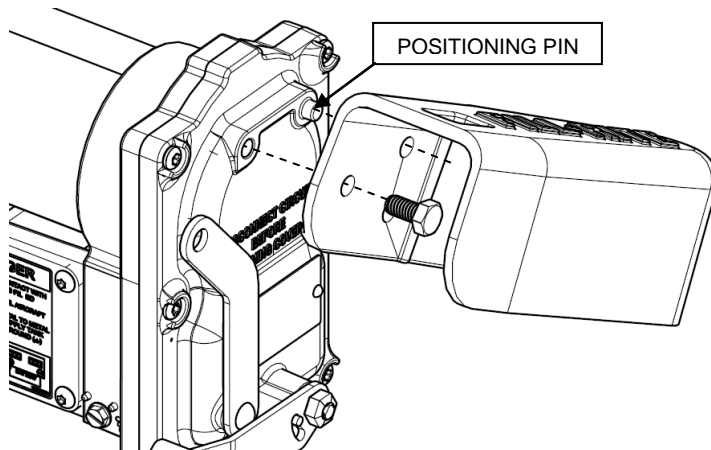

Install the first hole on the positioning pin that is part of the pump end cap casting. Install the attaching bolt in the hole nearest the open end of the nozzle boot. (\*A, B, and C series pumps have no positioning pin: use same holes and 2 bolts to attach boot.)

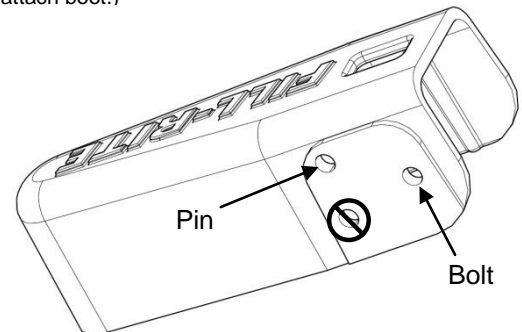

\*\*3200 uses same mounting holes but mounts longitudinally.

### 700 Series Nozzle Boot Installation

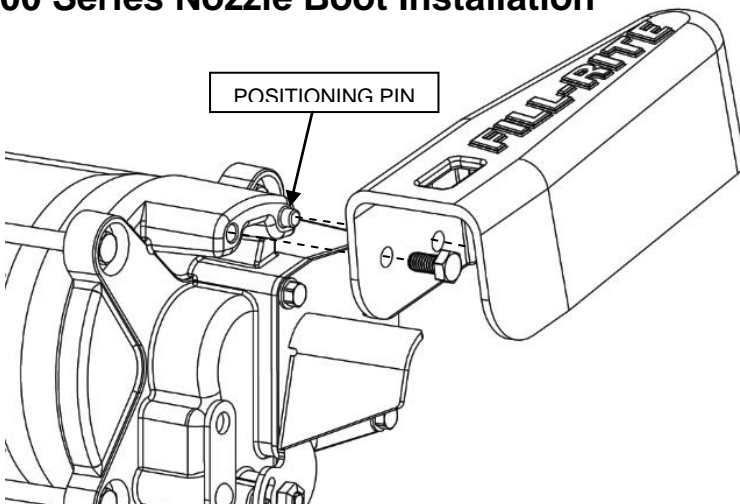

Install the first hole on the positioning pin that is part of the pump end cap casting. Install the attaching bolt in the hole nearest the open end of the nozzle boot.

