

FILL-RITE®

A GORMAN-RUPP COMPANY



NX25-120 SERIES BUNG MOUNT TECHNICAL SPECIFICATIONS



Motor	NX25-120
Power	115V AC 50/60Hz
HP (Horsepower) Rating	1/3 HP
Amps (FLA)	3.5
RPM	Variable 400 - 3500
Duty Cycle	Continuous for fuel transfer
Thermal Protection	Electronically protected
Certifications	UL/cUL motor

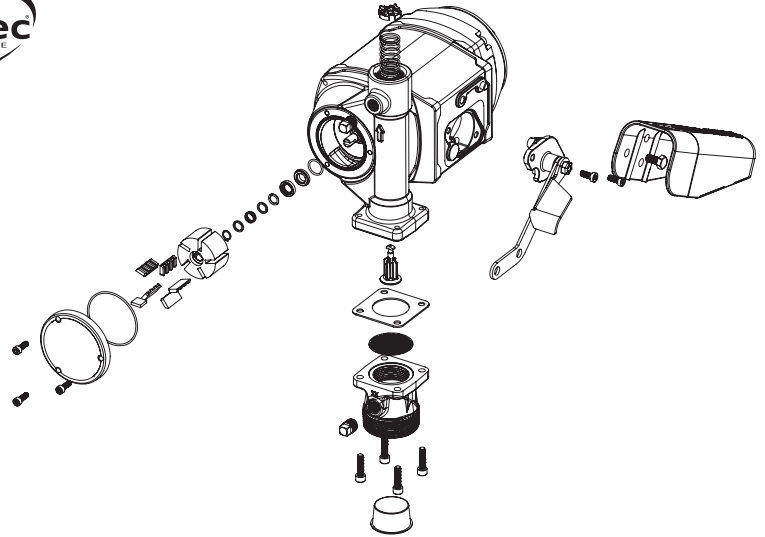

Pump	
Type / Design	Rotary vane
GPM in Supplied Configuration	25 GPM / 95 LPM*
Bypass Pressure Rating (PSI) - Max	25 PSI
Dry Vac (in Hg)	11
Head - Max	48.5'
Inlet - Size / Thread	1-1/4" NPT
Outlet - Size / Thread	1" NPT
Mount	2" NPT bung
Material - Pump Housing	Cast iron
Material - Wetted Material	Phenolic, stainless steel, steel, acetal, thermoset, Buna-N, fluorocarbon
Rotor Material	Powdered iron
Rotor Vane Material	Acetal
Compatible Fluids	Diesel, gasoline, biodiesel up to B20, E15, kerosene, mineral spirits, methanol (up to 15%)
Strainer Mesh Size	20 x 20
Warranty	Limited lifetime warranty†

SERVICE KIT INFORMATION

Kit	Description	Parts
KIT321RK	Overhaul Kit	Rotor, rotor cover, vanes, O-ring seal, shaft seal kit, bypass valve, inlet seal & screen, rotor key, attaching hardware
KIT321RG	Rotary Group	Rotor, vanes, rotor key, gasket, rotor cover, screws
KIT320SL	Shaft Seal	8-piece assembly
KIT321BV	Bypass Kit	Poppet, spring, O-ring, cap
KIT321NB	Boot Kit	Nozzle boot, attaching hardware
KIT321SK	External Seal Kit	Rotor cover, O-ring seal, inlet gasket, screen
KIT321BG	Inlet Kit	Inlet bung adapter, attaching hardware, inlet screen, seal
KIT321SW	Switch	Switch assembly
KIT321ASN	Anti-Siphon Kit	Anti-siphon hose, connectors
KIT321FLG	Meter Flange Kit	Meter flange, O-ring, screws
KIT321JC	Junction Box Kit	Junction box cover, O-ring, screws

*Adding accessories will affect flow rate
†Warranty details can be found at fillrite.com

DIMENSIONAL INFORMATION

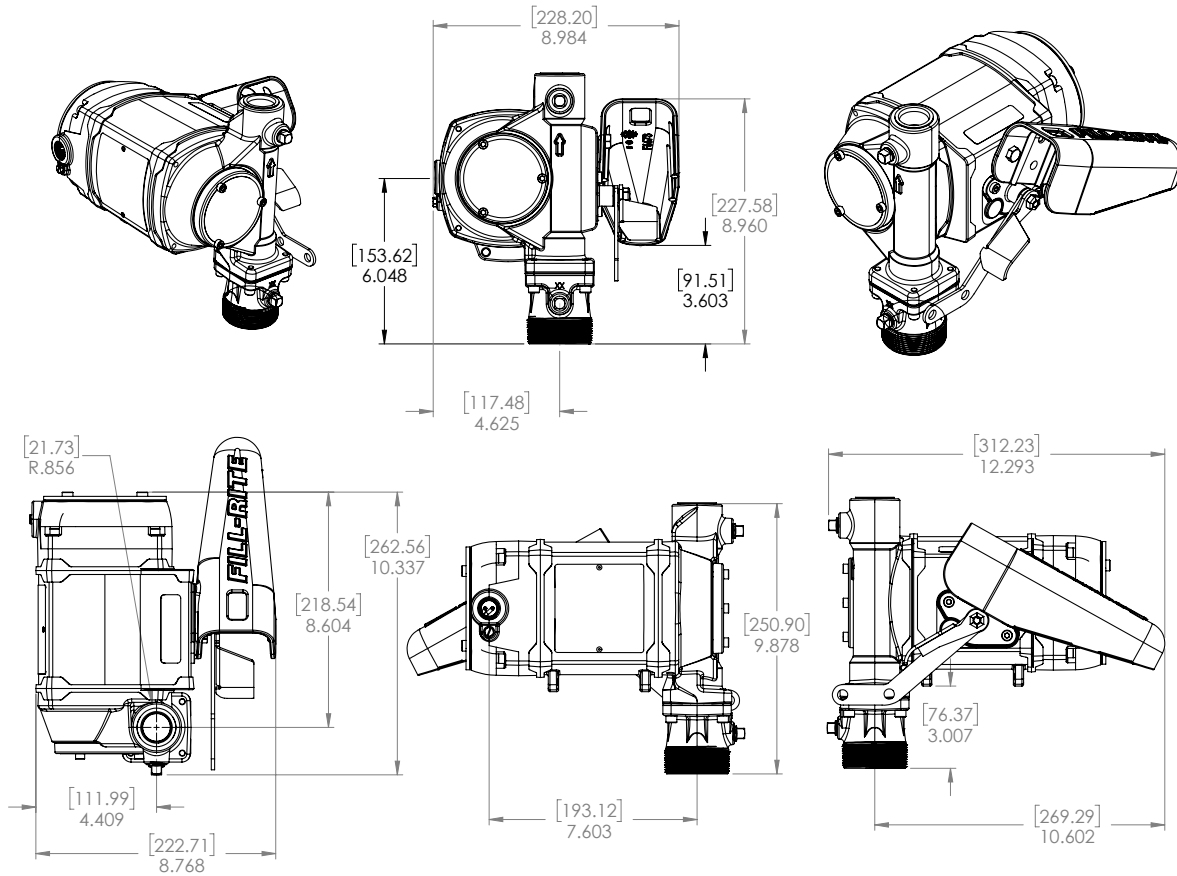

Measurements

Overall Height	9.878"
Overall Width	8.984"
Overall Depth	12.293"
Intake Center Line to Back of Nozzle Boot	10.602"
Product Weight	22.1 lbs / 10.0 kg
Qty per Pallet	16
Box Dimensions (LxWxH) - Pump Only	18" x 15-1/8" x 10"
Box Dimensions (LxWxH) - Full Kit	21-1/2" x 19-1/2" x 9-3/8"

Optional Accessories

Nozzle - Size	1" NPT-F inlet, 1-1/8" OD spout
Nozzle	Ultra high-flow automatic
Hose Diameter	1"
Hose Length	18'
Hose Material of Construction	Neoprene exterior
Hose Static Wire (Yes/No)	Yes
Certifications	UL/cUL listed

PERFORMANCE CURVE: NX25-120* SERIES

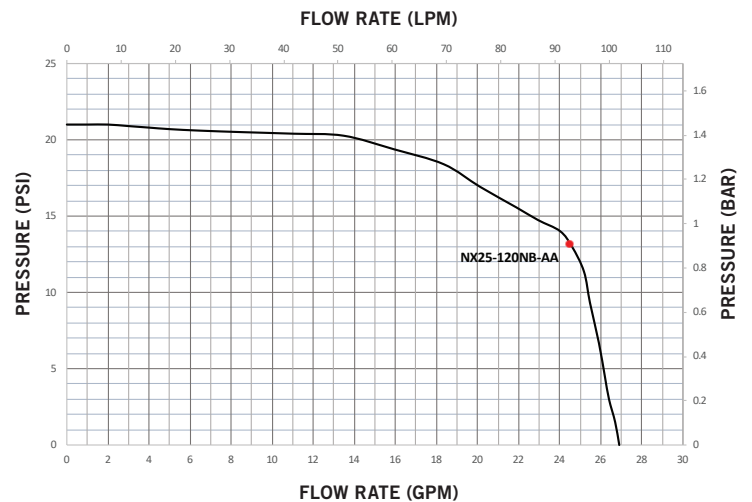

NX25-120 Pump Models

FIL-DS-564 Rev.2



CUSTOMER SUPPORT: (800) 634-2695
 TECHNICAL SUPPORT: (260) 747-7524

FILLRITE.COM

